

10W isolated DC-DC converter in DIP package,
Wide input and regulated dual/single output

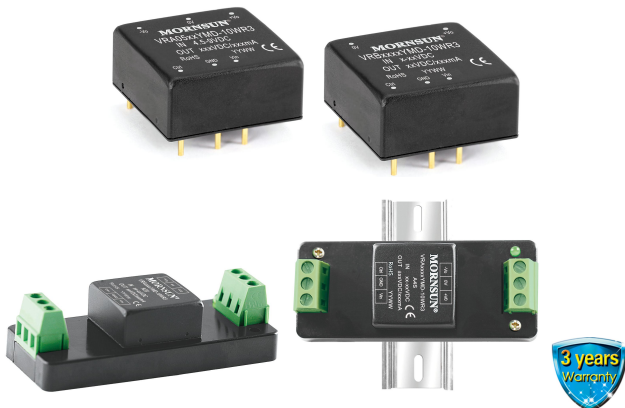

CE Patent Protection **RoHS**

FEATURES

- Wide 2:1 input voltage range
- High efficiency up to 88%
- No load power consumption as low as 0.12W
- I/O isolation test voltage 1.5k VDC
- Input under-voltage protection, output short-circuit, over-current, over-voltage protection
- Operating ambient temperature range: -40°C to +85°C
- Input reverse polarity protection available with chassis(A2S) or Din-Rail mounting(A4S) version
- Meets CISPR32/EN55032 CLASS A, without extra components
- Industry standard pin-out
- EN62368 approved

VRA_YMD-10WR3 & VRB_YMD-10WR3 series are isolated 10W DC-DC converter products with a 2:1 input voltage range. They feature efficiencies up to 88%, 1500VDC input to output isolation, operating temperature of -40°C to +85°C, input under-voltage protection, output over-voltage, over-current and short-circuit protection. They meet CLASS A CISPR32/EN55032 EMI standards(except 5VDC nominal input) without external components, optional packages are offered for chassis or DIN-rail mounting (A2S, A4S), adding additional input reverse polarity protection, which make them widely applied in applications such as industrial controls, electric power, instrumentation and communications.

Selection Guide

Certification	Part No. ①	Input Voltage (VDC)		Output		Full Load Efficiency ^④ (%) Min./Typ.	Max. Capacitive Load ^⑤ (μF)
		Nominal ^② (Range)	Max. ③	Voltage (VDC)	Current(mA) Max./Min.		
CE	VRA0505YMD-10WR3	5 (4.5-9)	12	±5	±1000/0	76/78	1000
	VRA0512YMD-10WR3			±12	±417/0	81/83	470
	VRA0515YMD-10WR3			±15	±334/0	82/84	330
	VRA0524YMD-10WR3			±24	±209/0	81/83	100
	VRB0505YMD-10WR3			5	2000/0	83/85	470
	VRB0512YMD-10WR3			12	834/0	81/83	470
	VRB0515YMD-10WR3			15	667/0	82/84	330
	VRB0524YMD-10WR3			24	417/0	81/83	100
CE ^⑦	VRB1205YMD-10WR3	12 (9-18)	20	5	2000/0	81/83	2200
CE	VRB2405YMD-10WR3	24 (18-36)	40	5	2000/0	81/83	2200
	VRB2412YMD-10WR3			12	833/0	85/87	470
	VRB2415YMD-10WR3			15	667/0	86/88	330
	VRB2424YMD-10WR3			24	416/0	86/88	100
-	VRB4803YMD-10WR3	48 (36-75)	80	3.3	2400/0	77/79	2200
	VRB4805YMD-10WR3			5	2000/0	81/83	2200
	VRB4812(X ^⑥)YMD-10WR3			12	833/0	85/87	470
	VRB4815(X)YMD-10WR3			15	667/0	85/87	330
	VRB4824YMD-10WR3			24	416/0	86/88	100

Notes:
 ① Use "A2S" suffix for chassis mounting and "A4S" suffix for Din-Rail mounting;
 ② The A2S and A4S Model's start-up and minimum input voltages are increased by 1VDC due to the input reverse polarity protection circuit;
 ③ Exceeding the maximum input voltage may cause permanent damage;
 ④ Efficiency is measured at nominal input voltage and rated output load; efficiencies for A2S and A4S Model's is decreased by 2% due to the input reverse polarity protection circuit;
 ⑤ The specified maximum capacitive load value for Vo1 and Vo2 output is identical;
 ⑥ "X" means product without Ctrl pin;
 ⑦ VRB1205YMD-10WR3 is designed according to EN62368 and meets EN62368 standards.

Input Specifications

Item	Operating Conditions		Min.	Typ.	Max.	Unit
Input Current (full load / no load)	5VDC nominal input series, nominal input voltage	5V output	--	2353/100	2410/150	mA
		Others	--	2500/10	2564/30	
	12VDC nominal input series, nominal input voltage		--	1004/5	1029/12	
	24VDC nominal input series, nominal input voltage		--	502/5	515/12	
	48VDC nominal input series, nominal input voltage	3.3V output	--	208/4	215/8	
Others		--	251/4	258/8		
Reflected Ripple Current	5VDC / 12VDC nominal input series		--	50	--	
	24VDC nominal input series		--	40	--	
	48VDC nominal input series		--	30	--	
Surge Voltage (1sec. max.)	5VDC nominal input series		-0.7	--	16	
	12VDC nominal input series		-0.7	--	25	
	24VDC nominal input series		-0.7	--	50	
	48VDC nominal input series		-0.7	--	100	
Start-up Voltage	5VDC nominal input series		--	--	4.5	VDC
	12VDC nominal input series		--	--	9	
	24VDC nominal input series		--	--	18	
	48VDC nominal input series		--	--	36	
Input Under-voltage Protection	5VDC nominal input series		3	3.5	--	
	12VDC nominal input series		5.5	6.5	--	
	24VDC nominal input series		12	15.5	--	
	48VDC nominal input series		26	30	--	
Start-up Time	Nominal input voltage & constant resistance load		--	10	--	ms
Input Filter			Pi filter			
Hot Plug			Unavailable			
Ctrl*	Module on		Ctrl pin open or pulled high TTL (3.5-12VDC)			
	Module off		Ctrl pin pulled low to GND (0-1.2VDC)			
	Input current when off		--	6	10	mA

Note: *The Ctrl pin voltage is referenced to input GND, VRB_XYMD-10WR3 series without Ctrl pin.

Output Specifications

Item	Operating Conditions		Min.	Typ.	Max.	Unit	
Voltage Accuracy	0%-100% load	5VDC input	Positive output	--	±1	±2	
			Negative output	--	±1	±3	
		Others		--	±1	±3	
Linear Regulation	Input voltage variation from low to high at full load	5VDC input	Singe output	--	--	±0.5	%
			Dual output	--	--	±1	
		Others		--	±0.2	±0.5	
Load Regulation ^①	0%-100% load	5VDC input	Singe output	--	--	±1	
			Dual output	--	--	±1.5	
	5%-100% load	12VDC/48VDC input		--	±0.5	±1	
	0%-100% load	24VDC input		--	±0.5	±1	
Cross Regulation	Input voltage range, 25%-100% load		--	--	±5		
Transient Recovery Time			--	300	500	μs	
Transient Response Deviation	25% load step change, nominal input voltage	±5V output, VRB4803YMD-10WR3, VRB4805YMD-10WR3		--	±5	±8	%
		Others		--	±3	±5	
Temperature Coefficient	Full load		--	--	±0.03	%/°C	
Ripple & Noise ^②	20MHz bandwidth, 5%-100% load		--	40	100	mV p-p	

Over-voltage Protection	Input voltage range	110	--	160	%Vo
Over-current Protection		110	140	190	%Io
Short-circuit Protection		Continuous, self-recovery			

Note: ① Load regulation for 0% -100% for 12VDC/48VDC nominal input series parts to $\pm 5\%$;
 ② Ripple & Noise at < 5% load is 5%Vo max. The "parallel cable" method is used for Ripple and Noise test, please refer to DC-DC Converter Application Notes for specific information.

General Specifications

Item	Operating Conditions	Min.	Typ.	Max.	Unit
Isolation	Input-output Electric Strength Test for 1 minute with a leakage current of 1mA max.	1500	--	--	VDC
Insulation Resistance	Input-output resistance at 500VDC	1000	--	--	MΩ
Isolation Capacitance	Input-output capacitance at 100kHz/0.1V	--	1000	--	pF
Operating Temperature	See Fig. 1	-40	--	+85	°C
Storage Temperature		-55	--	+125	
Storage Humidity	Non-condensing	5	--	95	%RH
Pin Soldering Resistance Temperature	Soldering spot is 1.5mm away from case for 10 seconds	--	--	+300	°C
Vibration		10-150Hz, 5G, 90 Min. along X, Y and Z			
Switching Frequency*	PWM mode	--	350	--	kHz
MTBF	MIL-HDBK-217F@25°C	1000	--	--	k hours

Note: *Switching frequency is measured at full load. The module reduces the switching frequency for light load (below 50%) efficiency improvement.

Mechanical Specifications

Case Material	Aluminum alloy				
Dimensions	Horizontal package		25.40 x 25.40 x 11.70 mm		
	A2S chassis mounting		76.00 x 31.50 x 21.20 mm		
	A4S DIN-rail mounting		76.00 x 31.50 x 25.80 mm		
Weight	VRB0505YMD-10WR3	Horizontal package/A2S wiring	15.0g /38.5g /58.5g (Typ.)		
	Others	package/A4S rail package	12.5g /36.0g /56.0g(Typ.)		
Cooling Method	Free air convection				

Electromagnetic Compatibility (EMC)

Emissions	CE	5VDC nominal input	CISPR32/EN55032 CLASS B (see Fig.5-② for recommended circuit)			
		12VDC nominal input	CISPR32/EN55032 CLASS A (without extra components.)/ CLASS B (see Fig.4-② for recommended circuit)			
		24VDC nominal input	CISPR32/EN55032 CLASS A (without extra components.)/ CLASS B (see Fig.3-② for recommended circuit)			
		48VDC nominal input	CISPR32/EN55032 CLASS B (see Fig.3-② for recommended circuit)			
RE		5VDC nominal input	CISPR32/EN55032 CLASS B (see Fig.5-② for recommended circuit)			
		12VDC nominal input	CISPR32/EN55032 CLASS A(without extra components.)/CLASS B(see Fig.4-② for recommended circuit)			
		24VDC nominal input	CISPR32/EN55032 CLASS A(without extra components.)/CLASS B(see Fig.3-② for recommended circuit)			
		48VDC nominal input	CISPR32/EN55032 CLASS B (see Fig.3-② for recommended circuit)			
Immunity	ESD	5VDC nominal input	IEC/EN61000-4-2	Contact $\pm 6kV$	perf. Criteria B	
		Others	IEC/EN61000-4-2	Contact $\pm 4kV$	perf. Criteria B	
	RS		IEC/EN61000-4-3	10V/m	perf. Criteria A	
	EFT	Others	IEC/EN61000-4-4	$\pm 2kV$ (see Fig.3-① for recommended circuit)		perf. Criteria B
		5VDC nominal input	IEC/EN61000-4-4	$\pm 2kV$ (see Fig.5-① for recommended circuit)		perf. Criteria B
		12VDC nominal input	IEC/EN61000-4-4	$\pm 2kV$ (see Fig.4-① for recommended circuit)		perf. Criteria B
	Surge	Others	IEC/EN61000-4-5	line to line $\pm 2kV$ (see Fig.3-① for recommended circuit)		perf. Criteria B
		5VDC nominal input	IEC/EN61000-4-5	line to line $\pm 2kV$ (see Fig.5-① for recommended circuit)		perf. Criteria B
		12VDC nominal input	IEC/EN61000-4-5	line to line $\pm 2kV$ (see Fig.4-① for recommended circuit)		perf. Criteria B

Immunity	CS	IEC/EN61000-4-6	3 V.r.m.s	perf. Criteria A
----------	----	-----------------	-----------	------------------

Typical Characteristic Curves

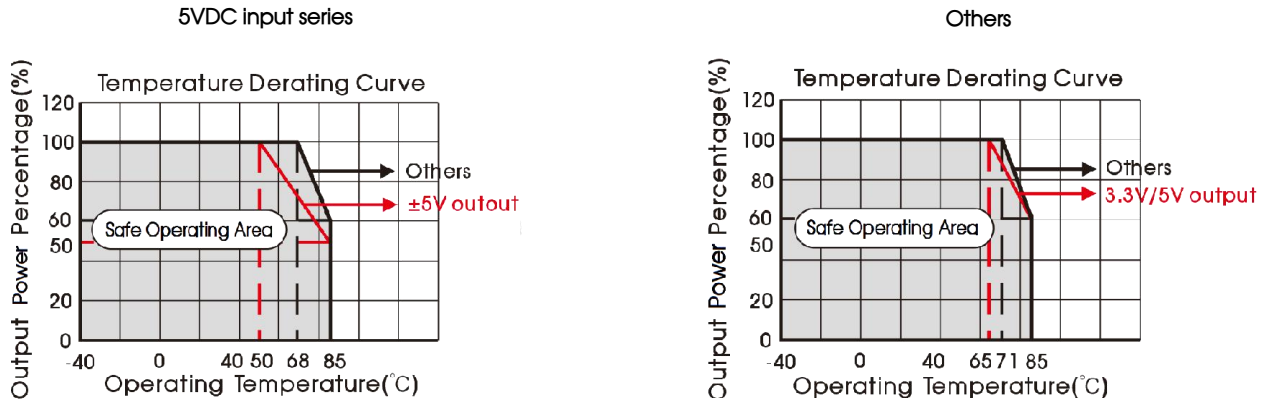
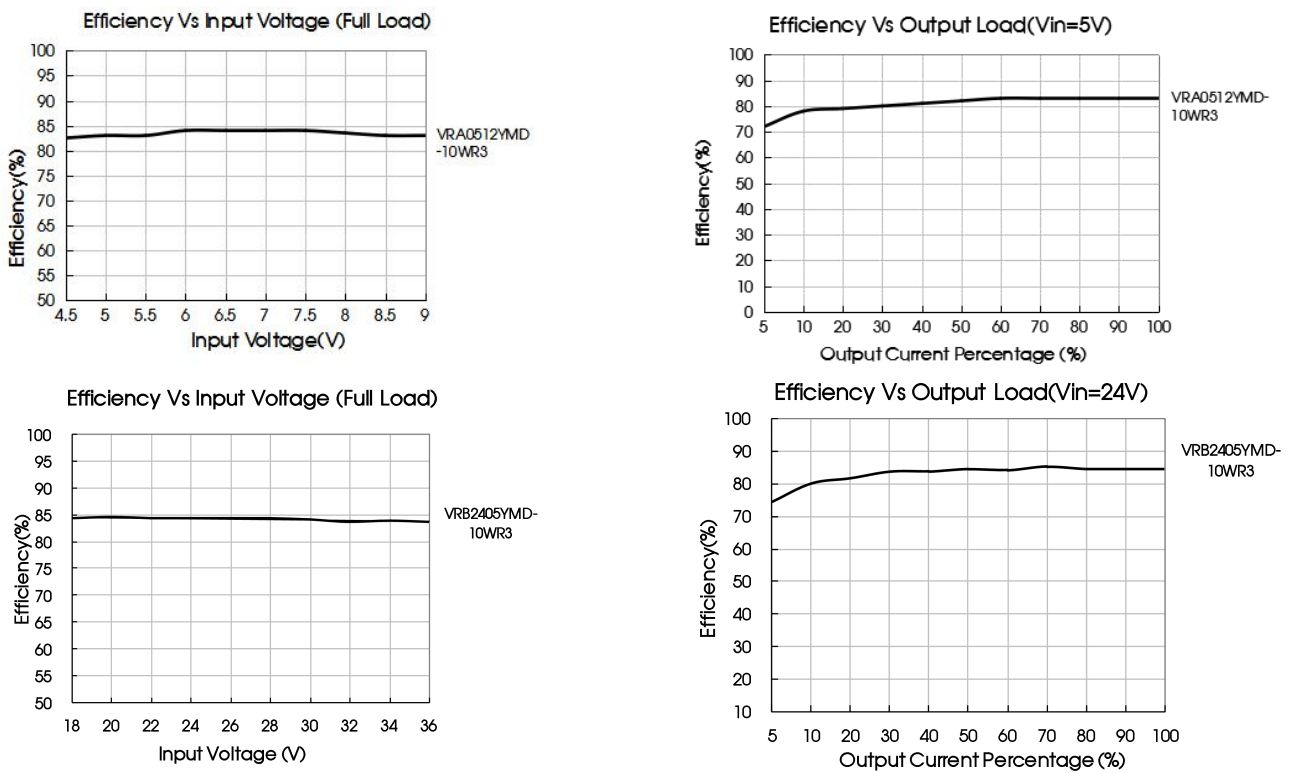

Fig. 1



Design Reference

1. Typical application

All DC-DC converters of this series are tested before delivery using the recommended circuit shown in Fig. 2.

Input and/or output ripple can be further reduced by appropriately increasing the input & output capacitor values C_{in} and C_{out} and/or by selecting capacitors with a low ESR (equivalent series resistance). Also make sure that the capacitance is not exceeding the specified max. capacitive load value of the product.

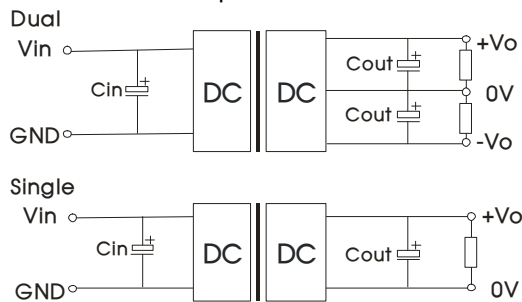

Fig. 2

Vin(VDC)	Cin(μ F)	Cout(μ F)
5	100 μ F/16V	Vo(3.3/5/ \pm 5):10 μ F/16V
12	100 μ F/25V	
24	100 μ F/50V	Vo(12/ \pm 12/15/ \pm 15V):10 μ F/25V
48	100 μ F/100V	Vo(24/ \pm 24V):10 μ F/50V

2. EMC compliance circuit

24VDC/48VDC nominal input series

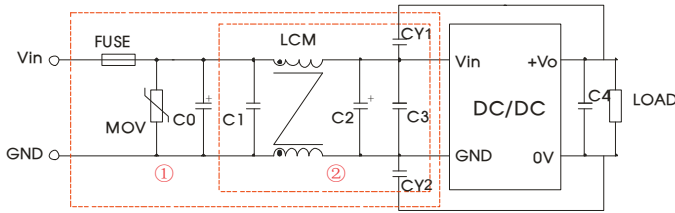

Fig. 3

Notes: For EMC tests we use Part ① in Fig. 3 for immunity and part ② for emissions test. Selecting based on needs.

Parameter description:

Model	Vin:24V	Vin:48V
FUSE	Select fuse value according to actual input current	
MOV	S20K30	S14K60
C0	680μF/50V	680μF/100V
C1	1μF/50V	1μF/100V
C2	330μF/50V	330μF/100V
C3	4.7μF/50V	4.7μF/100V
C4	Refer to the Cout in Fig.2	
LCM	4.7mH, recommended to use MORNSUN FL2D-30-472	
CY1, CY2	1nF/2kV	

12VDC nominal input series

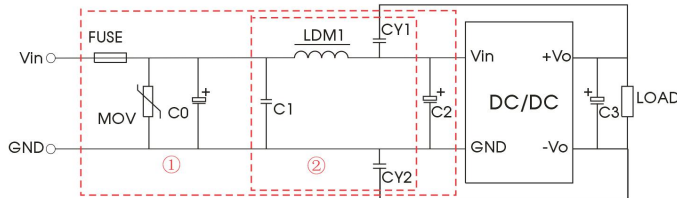

Fig. 4

Notes: For EMC tests we use Part ① in Fig. 4 for immunity and part ② for emissions test. Selecting based on needs.

Parameter description:

Model	Vin:12V
FUSE	Select fuse value according to actual input current
MOV	S20K30
C0, C2	330μF/50V
C1	1μF/50V
C3	Refer to the Cout in Fig.2
LDM1	4.7μH
CY1, CY2	1nF/2kV

5VDC nominal input series

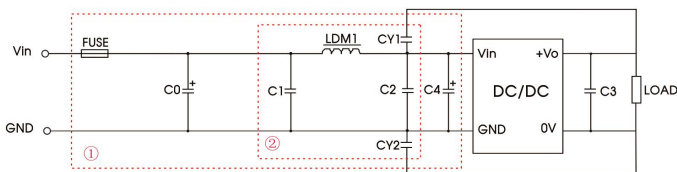

Fig. 5

Notes: For EMC tests we use Part ① in Fig. 5 for immunity and part ② for emissions test. Selecting based on needs.

Parameter description:

Model	Vin: 5V
FUSE	Select fuse value according to actual input current
C0	2200μF/35V
C1, C2	4.7μF/50V
C3	Refer to the Cout in Fig.2
C4	1000μF/35V
LDM1	4.7μH
CY1, CY2	1nF/2kV

3. The products do not support parallel connection of their output.

4. For additional information please refer to DC-DC converter application notes on www.mornsun-power.com

VRA(B)_YMD-10WR3 Dimensions and Recommended Layout

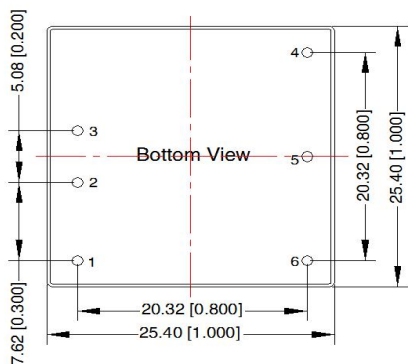
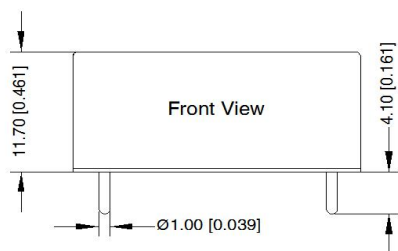

Note:
 Unit: mm[inch]
 Pin diameter tolerances: $\pm 0.10[\pm 0.004]$
 General tolerances: $\pm 0.50[\pm 0.020]$

THIRD ANGLE PROJECTION

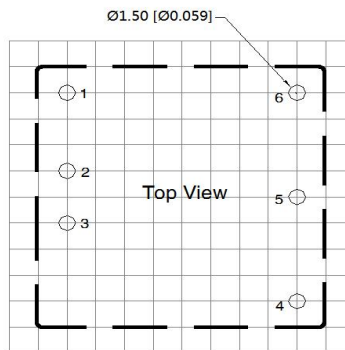

Note: Grid 2.54*2.54mm

Pin	Pin-Out	
	Single	Dual
1	Ctrl	Ctrl
2	GND	GND
3	Vin	Vin
4	+Vo	+Vo
5	No Pin	0V
6	0V	-Vo

VRB_XYMD-10WR3 Dimensions and Recommended Layout

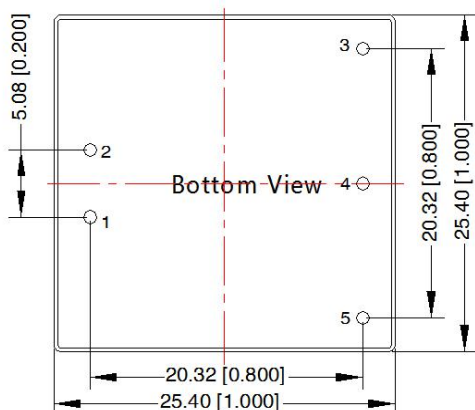
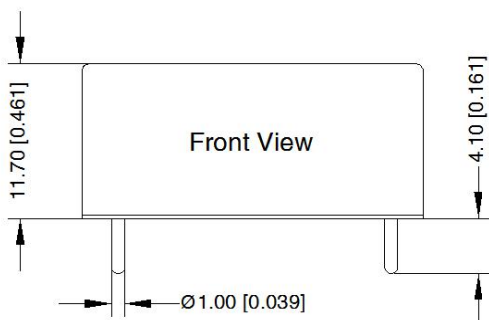

Note:
 Unit: mm[inch]
 Pin diameter tolerances: $\pm 0.10[\pm 0.004]$
 General tolerances: $\pm 0.50[\pm 0.020]$

THIRD ANGLE PROJECTION

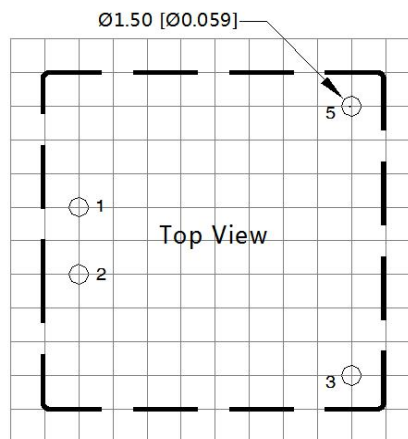

Note: Grid 2.54*2.54mm

Pin-Out	
Pin	Mark
1	GND
2	Vin
3	+Vo
4	No Pin
5	0V

VRA_YMD-10WR3A2S & VRB_YMD-10WR3A2S Dimensions

THIRD ANGLE PROJECTION

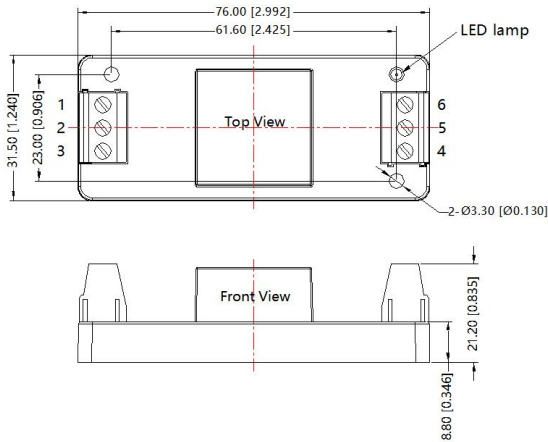

Pin-Out						
Pin	1	2	3	4	5	6
Single	Ctrl	GND	Vin	+Vo	NC	0V
Dual	Ctrl	GND	Vin	+Vo	0V	-Vo

Note:
Unit: mm[inch]
Wire range: 24-12 AWG
Tightening torque: Max 0.4 N·m
General tolerances: ±1.00[±0.039]

VRA_YMD-10WR3A4S & VRB_YMD-10WR3A4S Dimensions

THIRD ANGLE PROJECTION

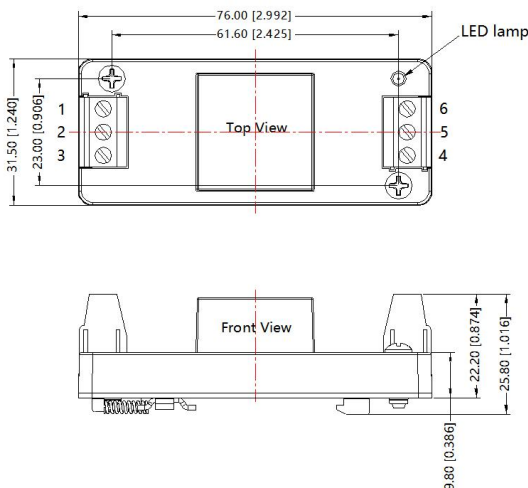

Pin-Out						
Pin	1	2	3	4	5	6
Single	Ctrl	GND	Vin	+Vo	NC	0V
Dual	Ctrl	GND	Vin	+Vo	0V	-Vo

Note:
Unit: mm[inch]
Mounting rail: TS35
Wire range: 24-12 AWG
Tightening torque: Max 0.4 N·m
General tolerances: ±1.00[±0.039]

Note:

- For additional information on Product Packaging please refer to www.mornsun-power.com. Packaging bag number: 58210003 (DIP); 58220022(A2S/A4S package);
- If the product is not operated within the required load range, the product performance cannot be guaranteed to comply with all parameters in the datasheet;
- The maximum capacitive load offered were tested at input voltage range and full load;
- Unless otherwise specified, parameters in this datasheet were measured under the conditions of $T_a=25^{\circ}\text{C}$, humidity<75%RH with nominal input voltage and rated output load;
- All index testing methods in this datasheet are based on company corporate standards;
- We can provide product customization service, please contact our technicians directly for specific information;
- Products are related to laws and regulations: see "Features" and "EMC";
- Our products shall be classified according to ISO14001 and related environmental laws and regulations, and shall be handled by qualified units.

Mornsun Guangzhou Science & Technology Co., Ltd.

Address: No. 5, Kehui St. 1, Kehui Development Center, Science Ave., Guangzhou Science City, Huangpu District, Guangzhou, P. R. China
Tel: 86-20-38601850 Fax: 86-20-38601272 E-mail: info@mornsun.cn www.mornsun-power.com