

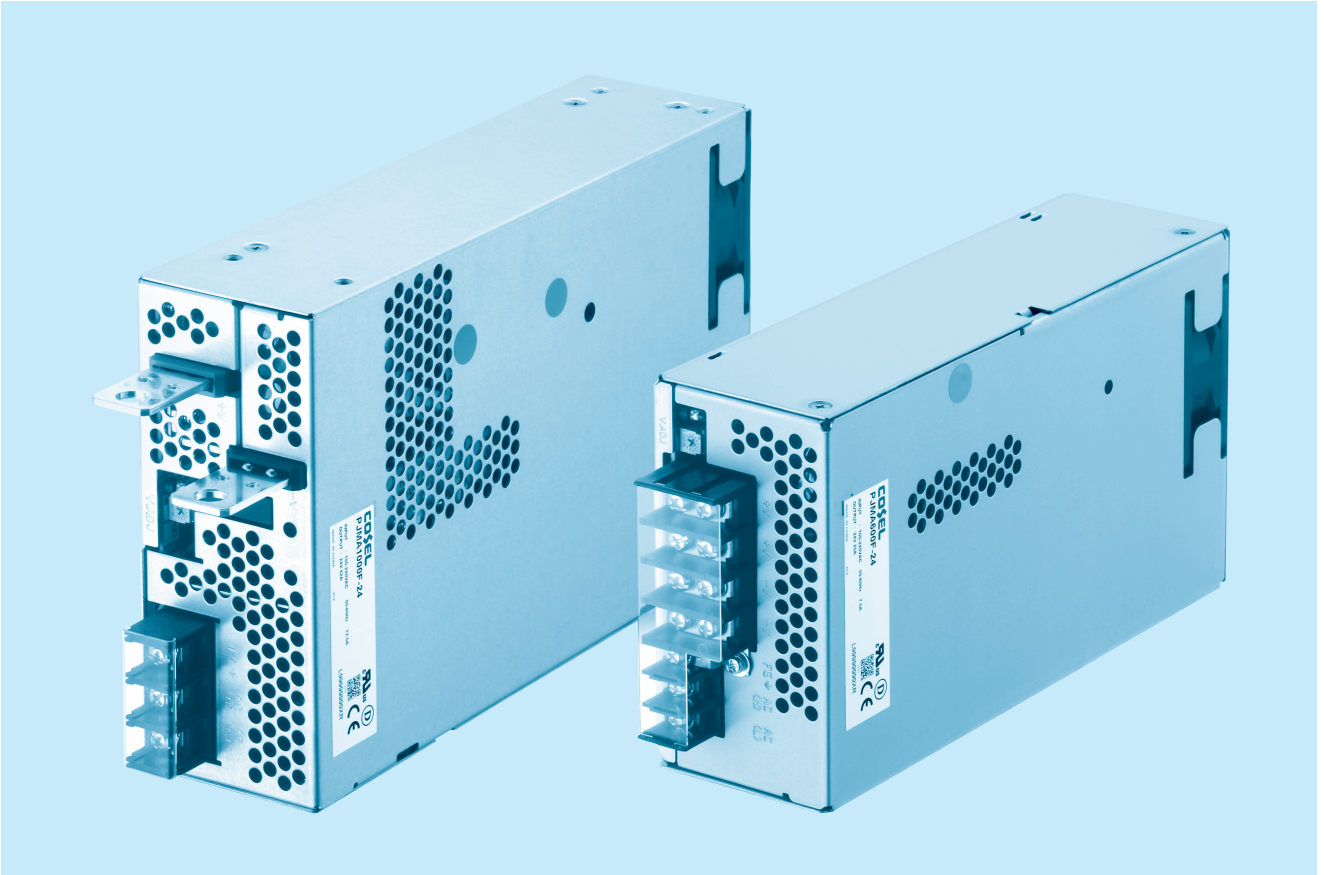

PJMA-series



Feature

- Medical Isolation Grade 2MOPP
- 4kV isolation
- Economical design
- Wide temperature range (-20°C to +70°C, Derating is required)
- Harmonic attenuator (Complies with IEC61000-3-2 class A)
- Universal input (AC85 - 264V, Derating is required)
- Low power consumption at no load

Safety agency approvals

ANSI/AAMI ES60601-1, EN60601-1 3rd

5-year warranty (See Instruction Manual)

CE marking

Low Voltage Directive
RoHS Directive

EMI

Complies with FCC-B, CISPR32-B, EN55011-B, EN55032-B, VCCI-B

EMS Compliance : EN61204-3, EN61000-6-2 IEC60601-1-2 (2014), IEC60601-1-2 (2015)

EN61000-4-2
EN61000-4-3
EN61000-4-4
EN61000-4-5
EN61000-4-6
EN61000-4-8
EN61000-4-11

PJMA600F

PJM A 600 F -□ -□
 ① ② ③ ④ ⑤ ⑥



Example recommended EMI/EMC filter
NAC-16-472



High voltage pulse noise type : NAP series
 Low leakage current type : NAM series
 * A higher current rating EMI/EMC filter may be recommended in view of the other devices that could be connected in parallel with the power supply.

- ① Series name
- ② Single output
- ③ Output wattage
- ④ Universal input
- ⑤ Output voltage
- ⑥ Optional *6
- C : with Coating
- G : Low leakage current
- V : External potentiometer for output voltage adjustment
- W1: LV alarm and Remote sensing
- R : Remote on/off (Required external power source)
- F4: Low speed fan

See 5.1 in Instruction Manual.

*Make sure necessary tests will be carried out on your end equipment with the power supply installed in accordance with any required EMC/EMI regulations.

SPECIFICATIONS

	MODEL	PJMA600F-12	PJMA600F-24	PJMA600F-36	PJMA600F-48	
INPUT	VOLTAGE[V]	AC85 - 264 1 φ (Output derating is required at AC85V - 100V. Refer to "Derating" and instruction manual 1.1)				
	CURRENT[A]	ACIN 100V	7.5typ (Io=100%)			
		ACIN 115V	6.5typ (Io=100%)			
		ACIN 230V	3.2typ (Io=100%)			
	FREQUENCY[Hz]	50 / 60 (47 - 63)				
	EFFICIENCY[%]	ACIN 100V	81typ (Io=100%)	84typ (Io=100%)	85typ (Io=100%)	85typ (Io=100%)
		ACIN 115V	82typ (Io=100%)	85typ (Io=100%)	86typ (Io=100%)	85typ (Io=100%)
		ACIN 230V	84typ (Io=100%)	88typ (Io=100%)	88typ (Io=100%)	88typ (Io=100%)
	POWER FACTOR	ACIN 100V	0.99typ (Io=100%)			
		ACIN 115V	0.98typ (Io=100%)			
ACIN 230V		0.95typ (Io=100%)				
INRUSH CURRENT[A]	ACIN 100V	20/40typ (Io=100%) (Primary inrush current /Secondary inrush current) (More than 3sec to re-start)				
	ACIN 115V	20/40typ (Io=100%) (Primary inrush current /Secondary inrush current) (More than 3sec to re-start)				
	ACIN 230V	40/40typ (Io=100%) (Primary inrush current /Secondary inrush current) (More than 3sec to re-start)				
LEAKAGE CURRENT[mA]	0.3max (ACIN 240V,60Hz,Io=100%)					
OUTPUT	VOLTAGE[V]	12	24	36	48	
	CURRENT[A]	ACIN 85-100V	Output derating is required at ACIN 100V or less (Refer to "Derating")			
		ACIN 100V-264V	50	25	16.7	12.5
	WATTAGE[W]	ACIN 85-100V	Output derating is required at ACIN 100V or less (Refer to "Derating")			
		ACIN 100V-264V	600	600	601.2	600
	LINE REGULATION[mV]	*7	48max	96max	144max	192max
	LOAD REGULATION[mV]	*7	100max	150max	150max	300max
	RIPPLE[mVp-p]	0 to +50°C	120max	120max	150max	150max
		*1 -20 to 0°C	160max	160max	160max	400max
	RIPPLE NOISE[mVp-p]	0 to +50°C	150max	150max	200max	200max
		*1 -20 to 0°C	180max	180max	240max	500max
	TEMPERATURE REGULATION[mV]	0 to +50°C	120max	240max	360max	480max
		*1 -20 to +50°C	180max	290max	440max	600max
	DRIFT[mV]	*2	48max	96max	144max	192max
	START-UP TIME[ms]	300typ (ACIN 100V, Io=100%)				
	HOLD-UP TIME[ms]	20typ (ACIN 100V, Io=100%)				
OUTPUT VOLTAGE ADJUSTMENT RANGE[V]	10.80 to 13.20					
OUTPUT VOLTAGE SETTING[V]	12.00 to 12.48		24.00 to 24.96		32.40 to 39.60	
PROTECTION CIRCUIT AND OTHERS	OVERCURRENT PROTECTION	Works over 105% of rating and recovers automatically				
	OVERVOLTAGE PROTECTION[V]	13.80 to 16.80	27.60 to 33.60	41.40 to 50.40	55.20 to 67.20	
	OPERATING INDICATION	LED (Green)				
	REMOTE SENSING	Optional (Option -W1)				
	REMOTE ON/OFF	Optional (Required external power source. Option -R)				
ISOLATION	INPUT-OUTPUT • RC	*3 AC4,000V 1minute, Cutoff=20mA, 2MOPP DC500V 50MΩmin				
	INPUT-FG	AC2,000V 1minute, Cutoff=20mA, 1MOPP DC500V 50MΩmin				
	OUTPUT • RC-FG	*3 AC1,500V 1minute, Cutoff=20mA, 1MOPP DC500V 50MΩmin				
	OUTPUT-RC	*3 AC500V 1minute, Cutoff=20mA, DC500V 50MΩmin				
ENVIRONMENT	OPERATING TEMP.,HUMID.AND ALTITUDE**	-20 to +70°C (Refer to "Derating"), 20 - 90%RH (Non condensing), 3,000m (10,000 feet) max				
	STORAGE TEMP.,HUMID.AND ALTITUDE	-20 to +75°C, 20 - 90%RH (Non condensing), 9,000m (30,000 feet) max				
	VIBRATION	10 - 55Hz, 19.6m/s ² (2G), 3minutes period, 60minutes each along X, Y and Z axes				
SAFETY AND NOISE REGULATIONS	IMPACT	196.1m/s ² (20G), 11ms, once each X, Y and Z axes				
	AGENCY APPROVALS	ANSI/AAMI ES60601-1, EN60601-1 3rd				
	CONDUCTED NOISE	Complies with FCC-B, VCCI-B, CISPR32-B, EN55011-B, EN55032-B				
	HARMONIC ATTENUATOR *9	Complies with IEC61000-3-2 class A				

PJMA1000F

PJM A 1000 F -□ -□
 ① ② ③ ④ ⑤ ⑥

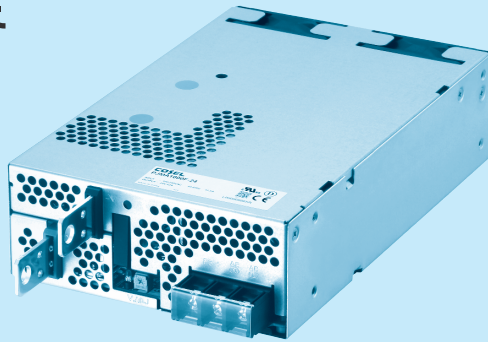

Example recommended EM/EMC filter
NAC-20-472



High voltage pulse noise type : NAP series
 Low leakage current type : NAM series

- ① Series name
- ② Single output
- ③ Output wattage
- ④ Universal input
- ⑤ Output voltage
- ⑥ Optional *8
- C : with Coating
- G : Low leakage current
- V : External potentiometer for output voltage adjustment
- W : Parallel operation, LV alarm and Remote sensing
- W1: LV alarm and Remote sensing
- R : Remote on/off (Required external power source)
- F4: Low speed fan

See 5.1 in Instruction Manual.

*Make sure necessary tests will be carried out on your end equipment with the power supply installed in accordance with any required EMC/EMI regulations.

SPECIFICATIONS

	MODEL	PJMA1000F-12	PJMA1000F-24	PJMA1000F-36	PJMA1000F-48	
INPUT	VOLTAGE[V]	AC85 - 264 1 φ (Output derating is required at AC85V - 115V. Refer to "Derating" and instruction manual 1.1)				
	CURRENT[A]	ACIN 100V	12.5typ (Io=90%)			
		ACIN 115V	11.0typ (Io=100%)			
		ACIN 230V	5.5typ (Io=100%)			
	FREQUENCY[Hz]	50 / 60 (47 - 63)				
	EFFICIENCY[%]	ACIN 100V	81typ (Io=90%)	84typ (Io=90%)	84typ (Io=90%)	84typ (Io=90%)
		ACIN 115V	82typ (Io=100%)	85typ (Io=100%)	85typ (Io=100%)	85typ (Io=100%)
		ACIN 230V	85typ (Io=100%)	88typ (Io=100%)	88typ (Io=100%)	88typ (Io=100%)
	POWER FACTOR	ACIN 100V	0.98typ (Io=90%)			
		ACIN 115V	0.98typ (Io=100%)			
ACIN 230V		0.95typ (Io=100%)				
INRUSH CURRENT[A]	ACIN 100V	15/30typ (Io=90%) (Primary inrush current /Secondary inrush current) (More than 10sec to re-start)				
	ACIN 115V	15/30typ (Io=100%) (Primary inrush current /Secondary inrush current) (More than 10sec to re-start)				
	ACIN 230V	30/30typ (Io=100%) (Primary inrush current /Secondary inrush current) (More than 10sec to re-start)				
LEAKAGE CURRENT[ma]	0.3max (ACIN 240V, 60Hz, Io=100%)					
OUTPUT	VOLTAGE[V]	12	24	36	48	
	CURRENT[A]	ACIN 85-115V	Output derating is required at ACIN 115V or less (Refer to "Derating")			
		ACIN 115V-264V	84	42	28	21
	WATTAGE[W]	ACIN 85-115V	Output derating is required at ACIN 115V or less (Refer to "Derating")			
		ACIN 115V-264V	1008	1008	1008	1008
	LINE REGULATION[mV]	*2	48max	96max	144max	192max
	LOAD REGULATION[mV]	*2	100max	150max	150max	300max
	RIPPLE[mVp-p]	0 to +50°C	180max	120max	150max	200max
		*1 -20 to 0°C	240max	160max	200max	500max
	RIPPLE NOISE[mVp-p]	0 to +50°C	210max	150max	200max	300max
		*1 -20 to 0°C	270max	180max	240max	600max
	TEMPERATURE REGULATION[mV]	0 to +50°C	120max	240max	360max	480max
		-20 to +50°C	180max	290max	440max	600max
	DRIFT[mV]	*3	48max	96max	144max	192max
	START-UP TIME[ms]	800typ (ACIN 115V, Io=100%)				
HOLD-UP TIME[ms]	20typ (ACIN 115V, Io=100%)					
OUTPUT VOLTAGE ADJUSTMENT RANGE[V]	10.80 to 13.50		20.40 to 28.50		30.60 to 40.80	
OUTPUT VOLTAGE SETTING[V]	12.00 to 12.48		24.00 to 24.96		36.00 to 37.44	
PROTECTION CIRCUIT AND OTHERS	OVERCURRENT PROTECTION	Works over 105% of rating and recovers automatically				
	OVERVOLTAGE PROTECTION[V]	14.40 to 17.40	28.80 to 34.80	43.20 to 52.20	57.00 to 67.20	
	OPERATING INDICATION	LED (Green)				
	REMOTE SENSING	Optional (Option -W, -W1)				
	REMOTE ON/OFF	Optional (Required external power source. Option -R)				
ISOLATION	INPUT-OUTPUT	AC4,000V 1minute, Cutoff=20mA, 2MOPP DC500V 50MΩ min				
	INPUT-FG	AC2,000V 1minute, Cutoff=20mA, 1MOPP DC500V 50MΩ min				
	OUTPUT · RC-FG	*3 AC1,500V 1minute, Cutoff=20mA, 1MOPP DC500V 50MΩmin				
	OUTPUT-RC	AC500V 1minute, Cutoff=20mA, DC500V 50MΩ min				
ENVIRONMENT	OPERATING TEMP., HUMID. AND ALTITUDE *4	-20 to +70°C (Refer to "Derating"), 20 - 90%RH (Non condensing), 3,000m (10,000 feet) max				
	STORAGE TEMP., HUMID. AND ALTITUDE	-20 to +75°C, 20 - 90%RH (Non condensing), 9,000m (30,000 feet) max				
	VIBRATION	10 - 55Hz, 19.6m/s ² (2G), 3minutes period, 60minutes each along X, Y and Z axes				
	IMPACT	196.1m/s ² (20G), 11ms, once each X, Y and Z axes				
SAFETY AND NOISE REGULATIONS	AGENCY APPROVALS	ANSI/AAMI ES60601-1, EN60601-1 3rd				
	CONDUCTED NOISE	Complies with FCC-B, VCCI-B, CISPR32-B, EN55011-B, EN55032-B				
	HARMONIC ATTENUATOR *5	Complies with IEC61000-3-2 class A				

SPECIFICATIONS

OTHERS	CASE SIZE/WEIGHT	150×61×240mm [5.91×2.40×9.45 inches] (Excluding terminal block and screw) (W×H×D) / 2.8kg max
	COOLING METHOD	*6 Forced cooling (internal fan)
WARRANTY	WARRANTY	*7 5 years (subject to the operating conditions)

*1 This is the result of measurement of the testing board with capacitors of 22 μF and 0.1 μF placed at 150 mm from the output terminals by a 20 MHz oscilloscope or a ripple-noise meter equivalent to Keisoku-Giken RM104.
See 1.6 of Instruction Manual for more details.

*2 Consult us about dynamic load and input response.

*3 Drift is the change in DC output for an eight hour period after a half-hour warm-up at 25°C.

*4 Output power derating is required. Refer to "Derating".

*5 Consult us about other classes.

*6 The fan speed slows down or stops at no load.

*7 See 3 in Instruction Manual for more details.

*8 Consult us about safety agency approvals for the models with optional functions.

* Do not use the power supply in overcurrent conditions or in unspecified input voltage ranges. Otherwise the internal components may be damaged.

* Parallel operation is not possible with this mode.

* Audible noise may be heard from the power supply when used for pulse load.

Features

- Medical Isolation Grade 2MOPP
- 4kV isolation
- Economical design
- Wide temperature range (-20°C to +70°C, Refer to "Derating")
- Harmonic attenuator (Complies with IEC61000-3-2 class A)
- Universal input (AC85 - 264V, Refer to "Derating")
- Low power consumption at no load

Block diagram

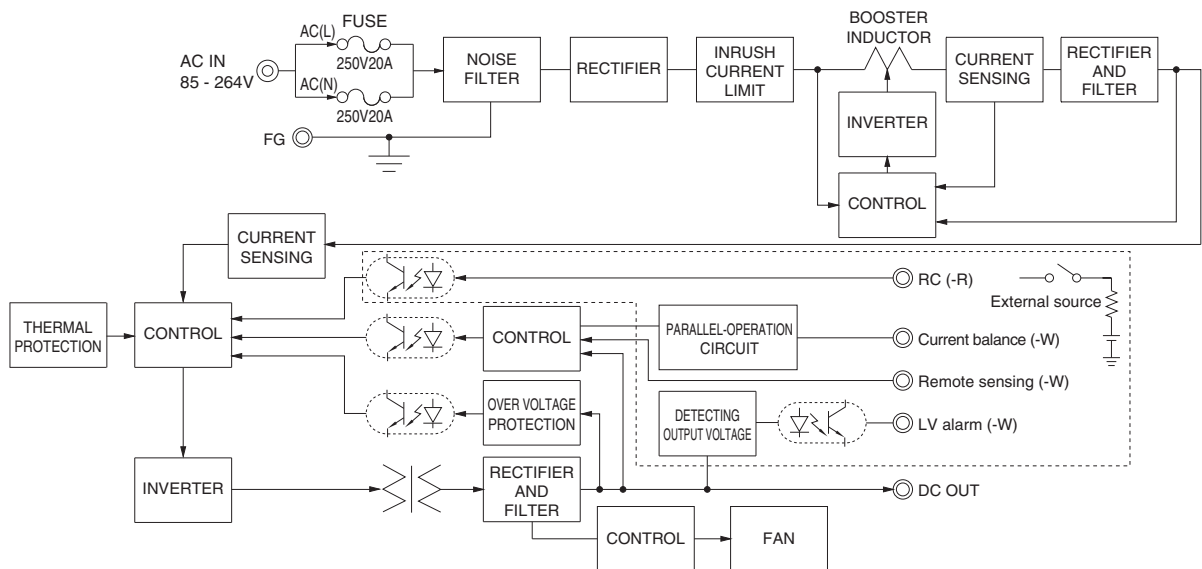

External view

The external size of -V option, -W option, -W1 option and -R option models is different from the standard model. See "5. Options and Others" in Instruction Manual for more details.

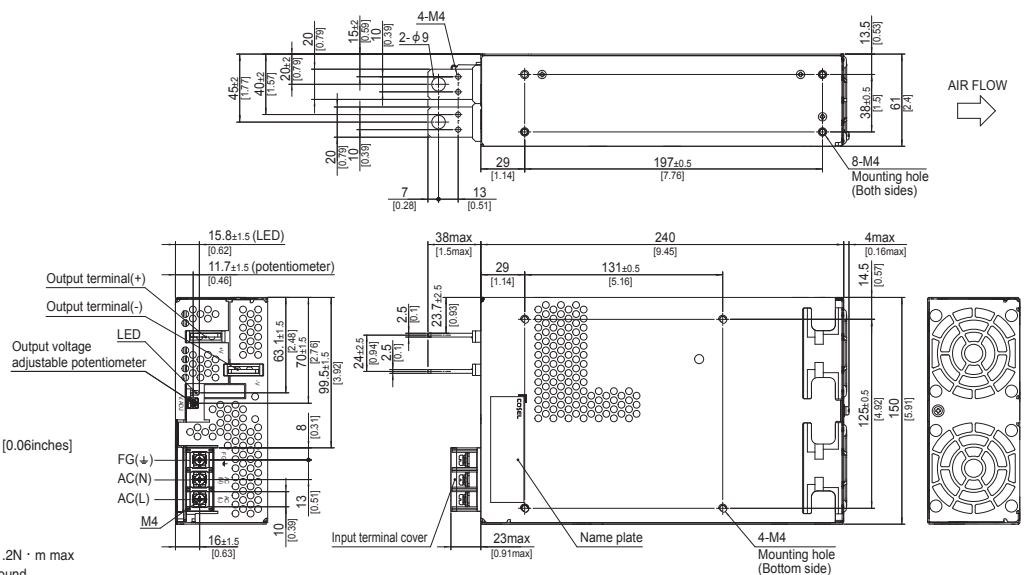

- ※Tolerance : ±1 [±0.04]
- ※Weight : 2.8kg max
- ※PCB Material/thickness : FR-4 / 1.6mm [0.06inches]
- ※Chassis material : Galvanizing steel
- ※Case material : Galvanizing steel
- ※Dimensions in mm, []=inches
- ※Mounting torque : 1.5N · m max
- ※Screw tightening torque : 1.6N · m max
- ※Output terminal M4 tightening torque : 1.2N · m max
- ※Connect the input FG to safety earth ground.

Assembling and Installation Method

- Do not insert a screw more than 6mm from the outside of a power supply to keep enough insulation distance between the screw and internal components.

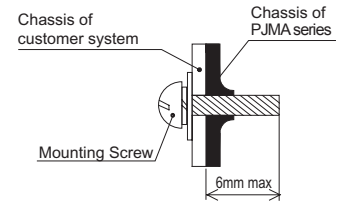

PJMA600F

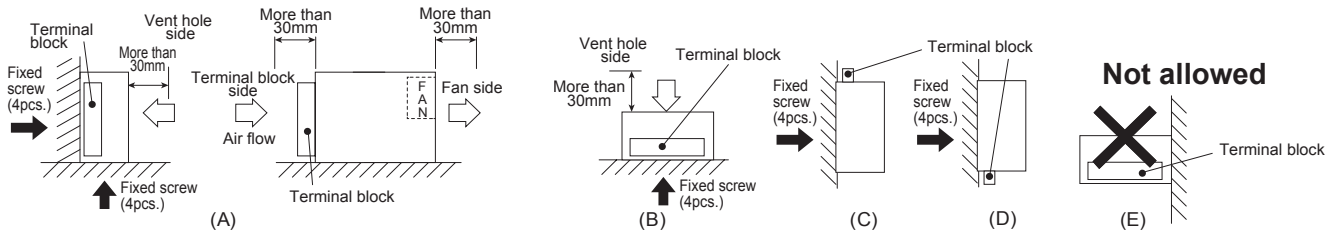

PJMA1000F

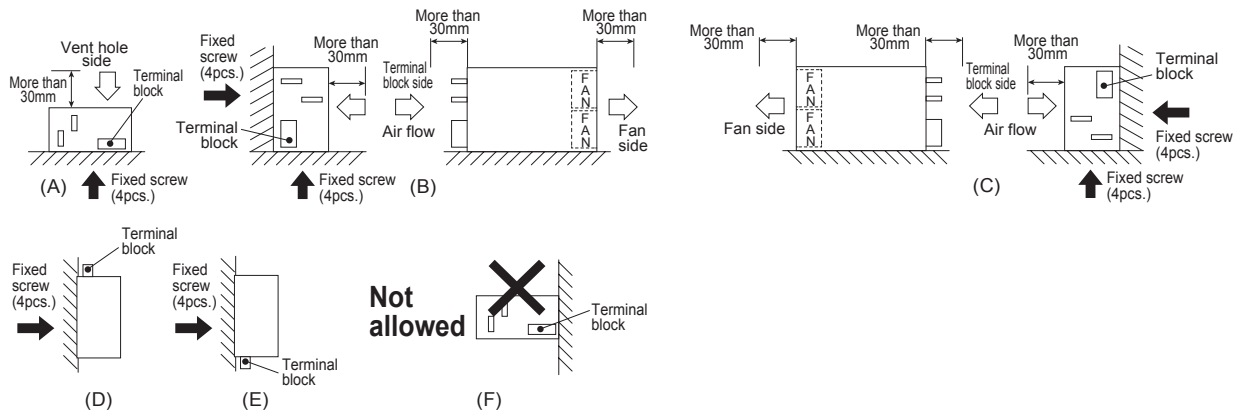

Assembling and Installation Method

- When mounting the power supply with screws, it is recommended that this be done as shown above. If other methods are used, be sure the weight of the power supply is taken into account.
- Avoid the not allowed installation method as it gives excessive stress to the mounting holes.
- Do not block air flow of the built-in fan (terminal block and ventilation hole).
- If the power supply is used in a dusty environment, use an airfilter. Make sure air flow is not blocked.
- If the built-in fan stops, thermal protection will work and the output will stop.
- The life expectancy (R(t)=90%) of the built-in fan varies depending on the operating condition.

Derating

● Input voltage Derating Curve

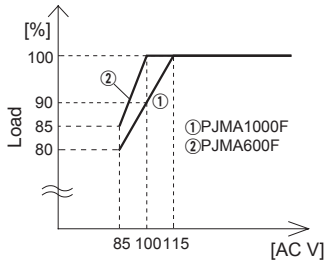

● PJMA600F/1000F Ambient temperature Derating Curve

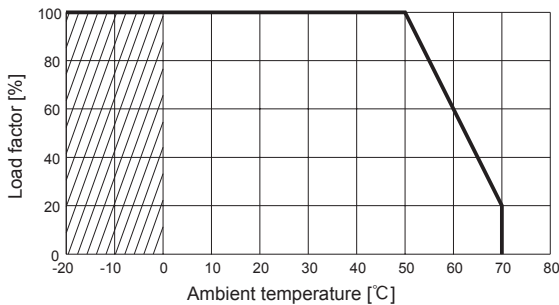

- In the hatched area, the specification of Ripple, Ripple Noise is different from other area.
- The ambient temperature is defined as the temperature of the air (at the terminal block side) that the built-in cooling fan blows into the power supply. Please pay attention to the heat generated by the input and output wires. Please consult us for more details.

Instruction Manual

◆ It is necessary to read the “Instruction Manual” and “Before using our product” before you use our product.

Instruction Manual <https://en.cosel.co.jp/product/powersupply/PJMA/>
 Before using our product <https://en.cosel.co.jp/technical/caution/index.html>

PJMA



NOTICE



Basic Characteristics Data

Model	Circuit method	Switching frequency [kHz]	Input current [A]	Rated input fuse	Inrush current protection circuit	PCB/Pattern			Series/Parallel operation availability	
						Material	Single sided	Double sided	Series operation	Parallel operation
PJMA600F	Active filter	60	7.5 *1	250V 16A	SCR	FR-4		Yes	Yes	No
	Forward converter	220						Yes	No	
PJMA1000F	Active filter	65	12.5 *2	250V 20A	TRIAC	FR-4		Yes	Yes	*3
	Forward converter	210						Yes	*3	

*1 The input current shown is at ACIN 100V and 100% load.
 *2 The input current shown is at ACIN 100V and 90% load.
 *3 Parallel operation is possible with -W option. see “5.Option and Other” is Instruction Manual.